

# Open Up the Ceiling With a Steel Sandwich

BY MICHAEL CHANDLER

**Bolted between rafters,  
an angled steel flitch  
plate can eliminate the  
need for rafter ties in  
cathedral ceilings**





**M**y company specializes in designing and building small homes. I like to vault ceilings in small rooms—bedrooms and screened porches, commonly—that normally would have flat ceilings.

People love cathedral ceilings because they add drama and presence to interior spaces. A vaulted ceiling can make a small room look large rather than cramped and confined. So why are cathedral ceilings usually reserved for living rooms or other large public areas while small rooms get stuck with flat ceilings? Cost.

Scissors trusses or structural ridge beams are the common, expensive methods for incorporating cathedral ceilings in houses. For the past few years, though, my company has overcome this economic problem by using angled steel flitch plates supplied by a steel fabricator. As shown in the drawing below, the V-shaped plate is angled to match the roof peak, and it's sandwiched between common rafters. Angled steel flitch plates work well for pyramid roofs but can be used to open gable roofs, too.

### Scissors trusses don't cut it

For years, I've been building vaulted ceilings using scissors-truss kits from my local truss supplier, but scissors trusses have a number of drawbacks: less space for insulation at the top plate, scheduling headaches, and cost. Did I mention that they're also a pain in the neck to install? Getting the little trusses to line up for a smooth

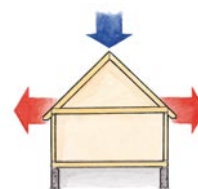

### Engineering a cathedral ceiling

The weight of a roof naturally causes rafters to thrust outward, which can push the walls apart. In a typical house ceiling, joists prevent the walls from spreading. In a cathedral ceiling, there are a few common ways to offset this outward thrust.



A **structural ridge** is a beam large enough to span the length of the house and support the weight of the roof.



**Rafter ties** provide tension force, which offsets the outward thrust and works for hip or gable roofs. The downside: horizontal framing members.



**Scissors trusses** are engineered to distribute forces internally on hip or gable roofs. The downsides: reduced ceiling pitch, difficult to drywall on hip roofs, expensive.

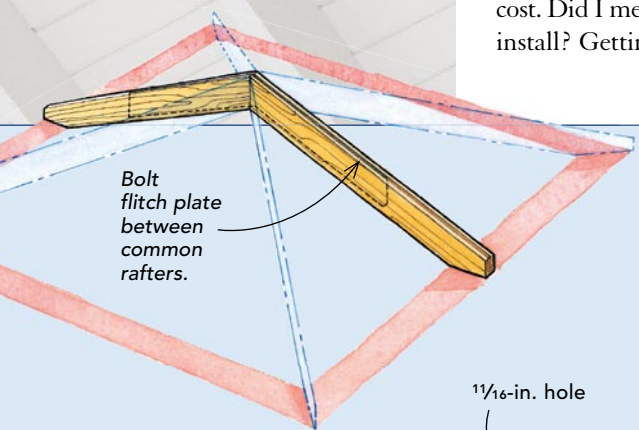

### A welded steel plate shoulders the roof load and unclutters the ceiling

A typical flitch plate is a straight piece of steel bolted between framing lumber. This modified design for a roof beam supports the framing while holding the walls together. This design works on hip roofs, gable roofs, or even shed-dormer retrofits. The benefits: inexpensive, open cathedral ceiling, readily available.

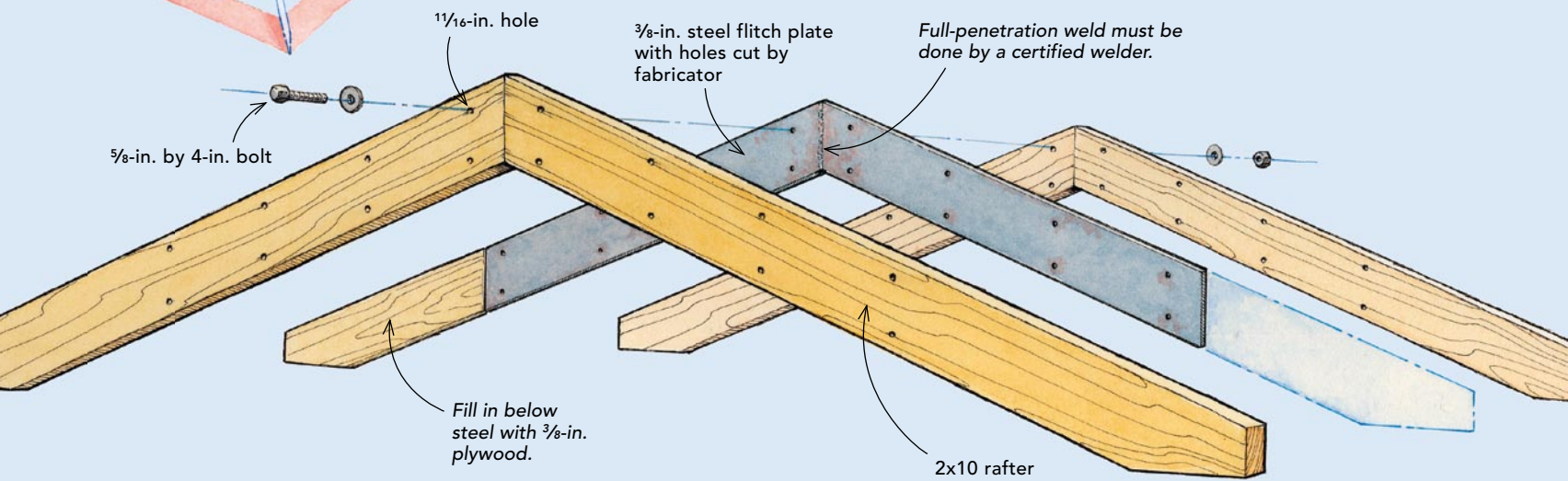



## MAKE THE STEEL SANDWICH ON TOP OF THE WALLS

**Tack the rafters flat.** After laying the rafters atop the wall plates and a temporary cat-walk, nail the plumb cuts tightly together. Align the seat cuts to their layout marks on the wall plates, and toenail as shown in the drawing on the facing page.



**Use the steel as a drilling template.** After laying the steel in place on top of the rafters, bore a hole at each end of the steel, then insert a bolt to hold the steel in place while the remaining holes are drilled.

roof and ceiling is fussy at best; my crew and I often have to strap the ceilings with 1x4s to get them smooth enough for drywall. The truss package for the last pyramid hip ceiling I built, for a 16-ft. by 16-ft. bedroom, cost \$1,600. The three-week lead time added insult to injury. There had to be a better way.

My engineer came up with an angled fitch-plate detail that creates a V-shaped beam capable of supporting 2x12 framing and that adds only \$180 to the framing costs. It's like a 160-lb. Simpson Strong Tie. The welding must be done by an American Welding Society certified welder using a full-penetration weld; you can't just do it on site. The first time I brought one of these angled-fitch drawings to my welder, he wanted a plywood template. Now I can fax him a diagram, and he has the fitch plate ready for me to pick up in a week, complete with clean holes.

This fitch solves all the problems of scissors trusses: It has a full 10 in. for insulation over the top plate, it keeps



**The steel is shorter than the rafters.** Fill in the ends of the steel plate with  $\frac{3}{8}$ -in. plywood and 1-in. roofing nails. After the top rafter is bolted in place, 8d nails driven from each side will hold the tails together.



**Complete the sandwich.** Clamp the top rafters in place, and drill up through the previously drilled holes. Again, make sure the plumb cuts are tight before drilling the holes.

the ceiling the same pitch as the roof, and it ensures that the roof and ceiling planes are smooth every time. Yes, the steel is heavy, and getting all those holes to line up takes some planning. But the assembled fitch beam is much less awkward to handle than scissors trusses, and it costs about \$1,000 less for that 16-ft. by 16-ft. room.

### The holes are bigger than the bolts

The holes in the steel should be cut by the fabricator, preferably with a high-pressure hydraulic "piranha" punch. Do not blast holes in the steel with a cutting torch because the holes will be ragged and will catch at the drill bit while you're using the steel as a template to drill holes into the wood.

When drilling through the rafters, use the same-size drill bit as the hole in the steel. This step ensures good contact for the bolt between the wood and the steel. The bolt, however, should be slightly smaller than the hole.



An  $\frac{1}{16}$ -in. hole in the steel requires a  $\frac{5}{8}$ -in. bolt. Undersizing the bolt more than that weakens the connection because the steel can move in the sandwich; undersizing the holes in the rafter can cause the wood to split when the bolts are tightened.

### Assemble the beam in place

Because the flitch weighs a lot (160 lb., in this case), the installation is not a one-person job. You'll need a helper or two to build this beam in place. I set up a temporary catwalk down the center of the room with a support post underneath. The catwalk needs to be stiff enough to support the framing lumber, the steel, a helper, and me.

With a catwalk ready, I set up my sandwich shop (photos facing page). I lay a couple of common rafters flat and tack them in place on the catwalk and wall tops. I tack the rafters to the wall plates so that the nail will act as a hinge—that is, the nail will hold the rafter in place during assembly and keep it from sliding when it's time to stand up the beam.

Next, I lay the steel on the rafters and drill down. To prevent the plate from shifting around, I drop several bolts into holes as I go. Having a helper comes in handy for more than just lifting the steel. A helper minimizes my number of trips up and down the ladder for bolts, nuts, washers, and plywood filler strips. Have a helper cut and fit  $\frac{3}{8}$ -in. plywood spacers as you drill holes.

With all the holes drilled in the lower-rafter pair, I pull the bolts (except for one in the tail of each rafter), lay the second rafter pair in position, and clamp them in place. The bolts remaining keep the parts aligned while the first couple of holes are drilled in the second rafter pair. Drill up from below at the peak, and set bolts in. After removing the first pair of bolts, I snug the second pair down to prevent drill vibration from causing the parts to lose alignment.

### Stand and brace the beam

Once all the bolts are tightened down, tilt the assembly upright and brace it well. It's not that heavy as long as the ends are well secured on the top plates. Have the bracing ready to nail as soon as the assembly is plumbed. Although 2x4 braces work fine, I like to set a perpendicular common rafter and a couple of hip rafters as bracing if I'm unable to finish the roof framing that day.

The rest is just regular hip-roof stick-framing except that the rafters are loaded in shear at the peak, so you need to use a hanger designed for shear load.

This type of roof assembly requires more uplift reinforcement than a comparable roof with ceiling joists that are used as collar ties, because there's less meat for toenailing into the top plate. For this reason, exceeding the code requirement for rafter tie-downs is a great idea. □

Michael Chandler owns Chandler Design-Build ([www.chandlerdesignbuild.com](http://www.chandlerdesignbuild.com)), near Chapel Hill, N.C. Photos by Daniel S. Morrison, except where noted. Technical assistance by Rob Munach, P.E.



## A NAIL HOLDS THE BEAM WHILE IT'S TILTED UP

Place the first rafter exactly on the layout line so that when it's rolled up, the rafter will be in the right place. Drive a 16d nail at an angle through the rafter and into the top plate. As the beam is lifted, the nail bends but keeps the rafter on its layout line. Have 2x4 braces on hand to nail into the beam after it's upright.

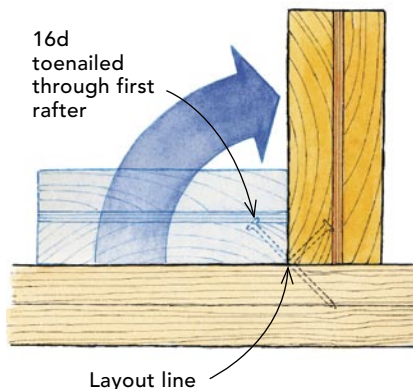

**Safety** Although it proved adequate to the task, the temporary catwalk shown in these photos would not have passed an OSHA inspection. The platform should have been 18 in. wide and constructed with scaffold-grade planks (typically a full 2 in. thick), not with conventional framing lumber.

## Use steel framing connectors for shear resistance

The steel flitch-beam assembly shoulders the shear load in one direction, but the intersecting hip rafters should be supported with a special framing anchor (the Simpson HRC22 hip-rafter connector) as well.

